

SIMPL-Intersection

A comprehensive and cost-effective solution for traffic detection and actuation

Highlights

- Provides the most precise multimodal detection and tracking (vehicles, trucks, buses, pedestrians, cyclists)
- AI Edge processing
- Easy to install and maintain
- Reliable in all weather and lighting conditions
- Integration with traffic light controllers for traffic actuation
- Privacy-friendly with no biometric data collected
- NEMA TS2 compliant



Perception and Detection Software

Object detection range from the stop bar	50 m pedestrians and cyclists 100 m all vehicle types
Multimodal classification types	Cars, trucks, buses, pedestrians, cyclists
Reliable in all conditions	Lighting: Day, night, sun glare Weather: rain, snow, fog, dust Object movement: moving and stationary
Configurable virtual loops/zones	Stop-bar Advanced detection (up to 100m or 300 feet) Crosswalk Sidewalk
Traffic light controller compatible	Yes (IP & i/o)
Analytics output (accessible with Seyond's Data & Analytics add-on module)	Vehicle classification Vehicle count Vehicle speed Vehicle trajectory Vehicle dimensions Vulnerable Road User classification Vulnerable Road User count

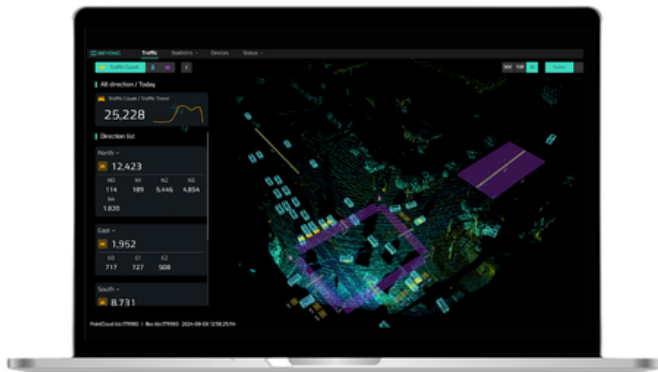

Falcon Prime LiDAR Sensor

NEMA TS2-2021 certified FALCON LiDAR sensors ensure reliable and industry-standard performance, providing confidence in safety and durability for all-weather and all-lighting conditions.

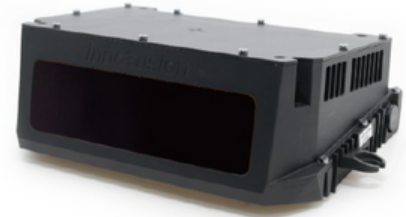

Distance Range (10% Reflectance) *	250m
Min ~ Max Range *	1.5 ~ 500 m
Field of View (HxV) *	120° x 25°
ROI Vertical Extent (Zone 1 + 2) *	9.6°
Number of scan lines *	148
ROI Zone 2 Resolution (HxV) *	0.1° x 0.1°
ROI Zone 1 Resolution (HxV) *	0.1° x 0.15°
Non-ROI Resolution (HxV) *	0.2° x 0.24°
Frame Rate *	10 FPS
Distance Accuracy	±5 cm (±10cm for retroreflectors)
Distance Precision	2 cm (1s at 50m)
Power Consumption	35 W
Input Voltage	9 ~ 34 V DC (24V recommended)
Dimensions (H x W x D)	84 x 228 x 150 mm
Weight	2.3 kg
Data Interface	1000 Base T Ethernet RJ45/M12 (UDP,TCP)
Data Output	3D Points, Intensity or Reflectivity
Time Synchronization	PTP, gPTP
Operating Temperature	-40 to 70°C
Ingress Protection	IP67 (body), IP69K (window)
Laser Wavelength	1550nm
Laser Safety	IEC-60825, Class 1
Warranty	3-year standard warranty, extendible to 5 years.
Certification	NEMA TS2 Certified.

LIDAR Sensor Dimensions (Unit: mm)

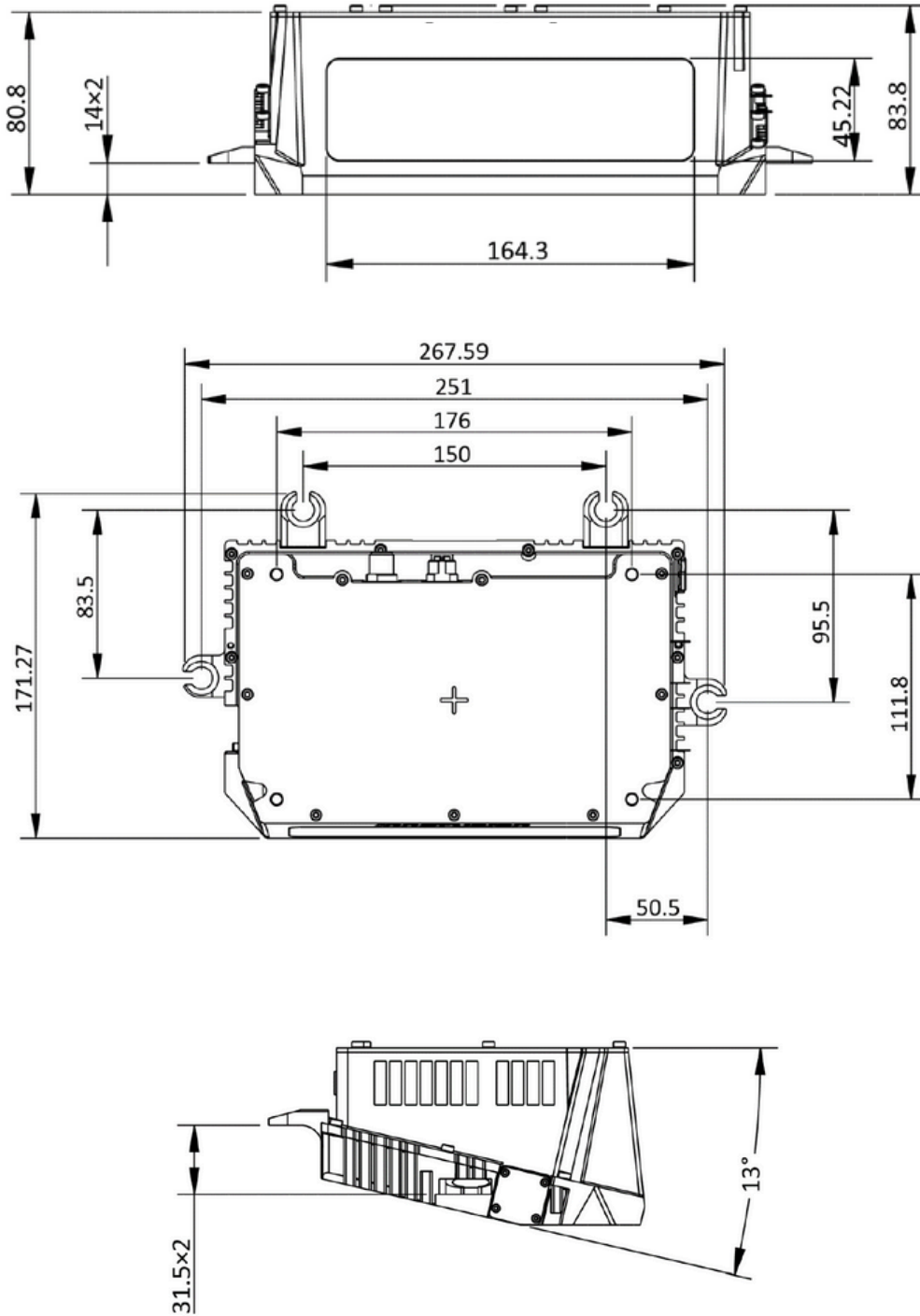

*Specifications are subject to change without notice and based on engineering targets. Specs are not guaranteed to have passed full validation at the time of publication.

Edge Device

Seeyond uses NEMA TS2 AI Inference System based on NVIDIA® Jetson AGX Orin™.

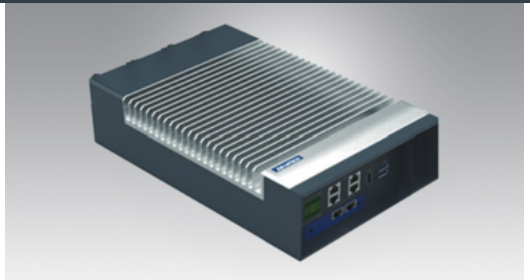

	NVIDIA® Jetson AGX Orin™ - MIC-733-A06A1
NVIDIA Jetson Series	AGX Orin 32G
CPU	8-core NVIDIA Arm® Cortex A78AE v8.2 64-bit CPU, 2MB L2 + 4MB L3
GPU	1792-core NVIDIA Ampere GPU with 56 Tensor Cores, Maximum Operating Frequency: 930 MHz
AI Performance Reference	Up to 200 TOPs
Memory	32GB 256-bit LPDDR5 DRAM
Ethernet	4 x 10/100/1000 Mbps (Support 4 x Gigabit PoE/2 Gigabit PoE+ with 60W power budget)
Display	HDMI (Max. resolution 3840x2160 @ 60Hz)
USB	2 x USB 3.0
Digital I/O	4-ch DI, 4-ch DO
Power Switch	1 x Power ON/OFF Button
Serial Ports	2 x RS-232/422/485 (On-board pin header)
OTG USB	1 x Micro USB
iModule (Optional)	1 x PCIe x8 (MIC-75M10-00A2)
Mini PCIe	2 x mPCIe (Signal: PCIe+USB)
SIM	2 x Nano SIM slots
M.2 (Expansion)	1 x M.2 3052 (B-Key, Signal: USB)
TPM (Optional)	1 x TPM 2.0
iDoor (Optional)	1 x iDoor bracket reserve
M.2 (Storage)	1 x M.2 3052 (B-Key, Signal USB)
SD Card	1 x Micro SD slot
Power Mode	AT/ATX (Default AT)
Input Voltage	12 Voc (With external 240W Adapter)
Operating Temperature	-34 ~ +74 °C with 0.7 m/S airflow (30W AGX Orin mode)
Operating Humidity	95% @ 40 °C (non-condensing)
Vibration	3Grms @ 5 ~ 500 Hz, random, 1 hr/axis
Shock	10G / 11 ms
Dimensions (W x D x H)	192 x 290 x 87 mm
Weight	4.5 kg (9.9 lb)
Installation	Desktop / Wall mount
Jetpack	Above 5.0
Certifications	UL/CB/CE/FCC/BSMI/CCC (No RED certification)

Edge Device Dimensions (Unit: mm)

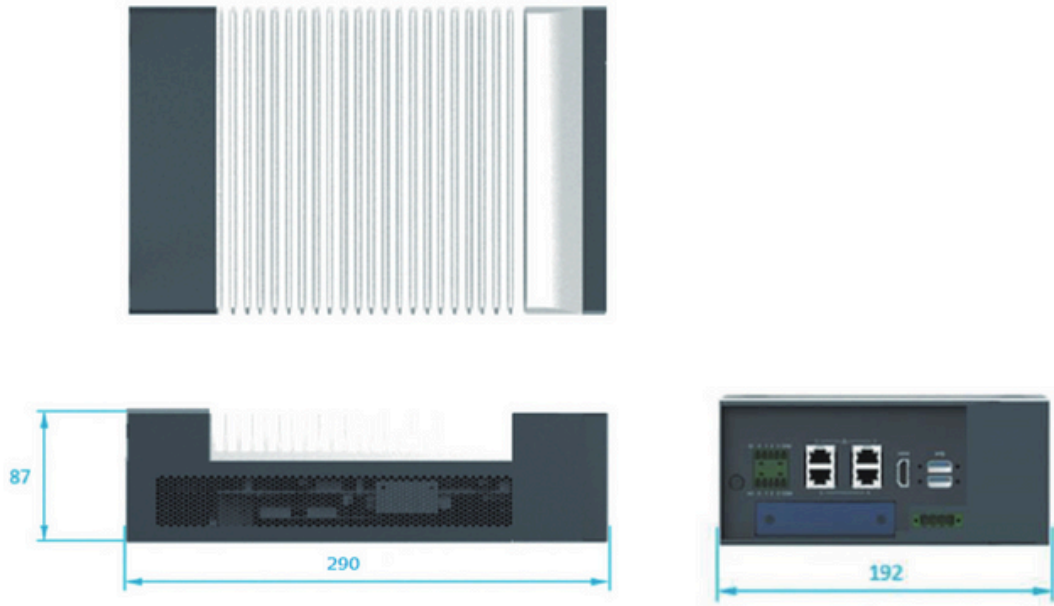

Mounting Arm (Unit: inch)

